

530 & 535 Series

Light Commercial Plaster Ceiling



Commercial 'T' Bar Ceiling



Open Ceiling

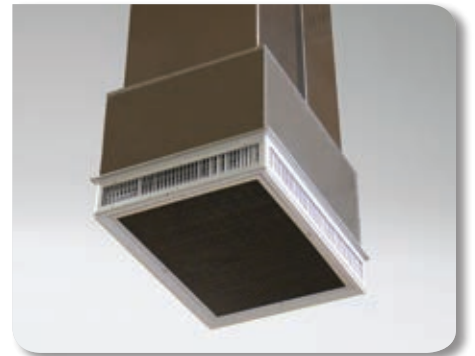

RRS's 530 & 535 SERIES concentric diffuser systems are designed to provide a single point air distribution system with the added benefit of having directional air control. The systems may be used with either a "T-Bar" ceiling, a plaster ceiling, or with no ceiling at all.

535 Series — Same as the 530 series, with an additional 1" Hogs Hair filter in the return section.

Standard features include:

- All aluminum diffuser frame with aluminum return air egg crate.
- Double deflection diffuser with the blades secured by spring steel.
- Built-in Anti-Sweat gasket.
- Molded Fiberglass Transition (through five tons).
- Built-in hanging supports.
- Diffuser box constructed of fiberglass ductboard (through 7.5 tons) or sheetmetal.

Standard benefits include:

- Even four (4) way air distribution.
- All exposed surfaces (below ceiling) are brushed aluminum.
- Factory assembled and sealed.
- Guaranteed not to "sweat".
- Guaranteed not to recirculate airflow (short cycle).
- Return air eggcrate is easily removed.
- Units are fully insulated (both supply and return).
- Lightweight design.

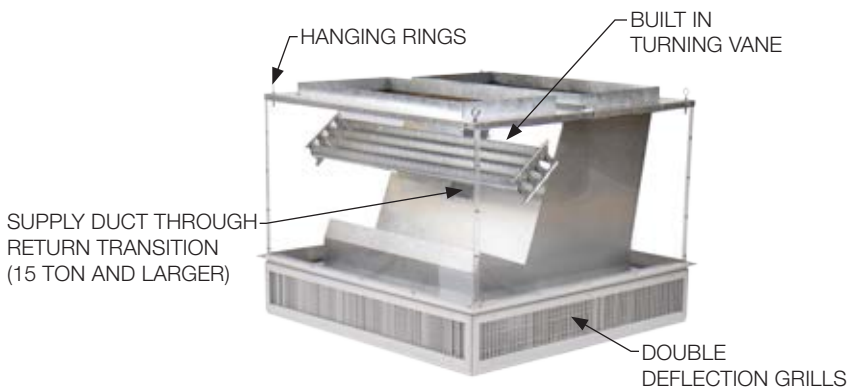

SIDE DISCHARGE CONCENTRIC DIFFUSER SYSTEM WITH FILTER GRILL

Typical specifications

Furnish and install Ruskin Rooftop Systems **"530 & 535 SERIES"** concentric diffuser systems. The system shall consist of an aluminum double deflection supply diffuser with an aluminum eggcrate return. ALL EXPOSED SURFACES (BELOW CEILING) MUST BE BRUSHED ALUMINUM. It shall also have a permanent (not adhesive) anti-sweat gasket and hanging supports. All units that are five (5) tons and smaller shall have a molded fiberglass interior transition.

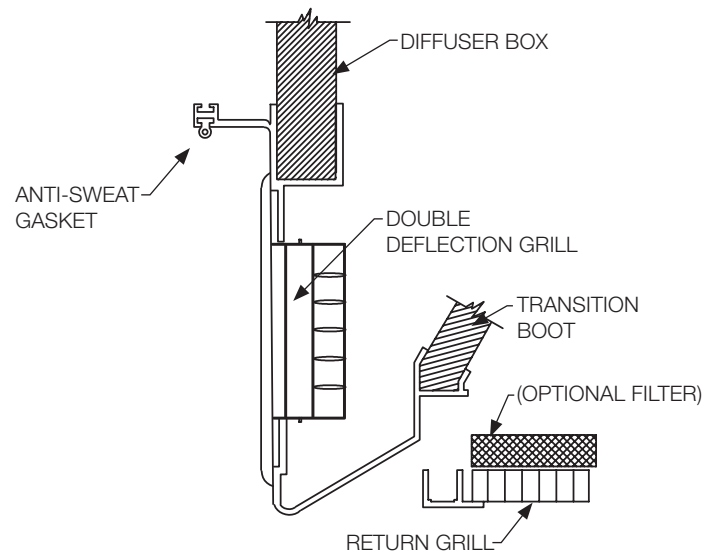

530 & 535 Series Concentric Diffuser Engineering Data

RSI PART NO.	CFM	STATIC PRESSURE	THROW FEET	NECK/JET VELOCITY	NOISE LEVEL	UNIT WEIGHT
01-530-16 01-535-16	600	0.09	8-15	210	20	38.00
	800	0.11	9-16	281	20	38.00
01-530-18 01-535-18	1000	0.14	10-17	351	20	38.00
	1200	0.17	11-18	421	20	38.00
01-530-20 01-535-20	1200	0.17	11-18	421	20	38.00
	1400	0.20	12-19	491	20	38.00
	1600	0.24	12-20	561	20	38.00
	1800	0.30	13-21	632	20	38.00
	2000	0.36	14-23	702	20	38.00
	2200	0.40	16-25	772	20	38.00
01-530-22 01-535-22	2600	0.17	24-29	669	20	82.00
	2800	0.20	25-30	720	25	82.00
	3000	0.25	27-33	772	25	82.00
	3200	0.31	28-35	823	25	82.00
	3400	0.37	30-37	874	30	82.00
	3600	0.17	25-33	851	30	122.00
01-530-50 01-535-50	3800	0.18	27-35	898	30	122.00
	4000	0.21	29-37	946	30	122.00
	4200	0.24	32-40	993	30	122.00
	4400	0.27	34-42	1040	30	122.00
	4600	0.31	26-31	841	30	145.00
01-530-80 01-535-80	4800	0.32	27-32	878	30	145.00
	5000	0.34	28-33	915	30	145.00
	5200	0.36	28-34	951	30	145.00
	5400	0.39	29-35	988	30	145.00

RSI PART NO.	CFM	STATIC PRESSURE	THROW FEET	NECK/JET VELOCITY	NOISE LEVEL	UNIT WEIGHT
01-530-60 01-535-60	5600	0.36	39-49	920	30	217.00
	5800	0.39	42-51	954	30	217.00
	6000	0.42	44-54	1022	30	217.00
	6200	0.46	45-55	1056	30	217.00
	6400	0.50	46-55	1090	30	217.00
	6600	0.54	47-56	1124	30	217.00
01-530-80 01-535-80	7200	0.39	33-38	827	25	238.00
	7600	0.43	36-41	873	25	238.00
	8000	0.50	39-44	918	30	238.00
	8400	0.56	43-49	964	30	238.00
	8800	0.63	47-55	1010	30	238.00
	9200	0.74	49-57	1056	50	238.00
01-530-100 01-535-100	9400	0.80	50-58	1079	55	238.00
	9600	0.83	52-62	1102	55	238.00
	9800	0.86	55-63	1125	55	238.00
	10000	1.00	57-65	1148	55	238.00
	10200	1.07	60-68	1171	60	238.00
	10400	1.16	63-71	1194	60	238.00
01-530-300 01-535-300	10000	.51	46-54	907	30	285.00
	10500	.58	50-58	953	30	285.00
	11000	.65	53-61	998	30	285.00
	11500	.73	55-64	1043	30	285.00
	12000	.82	58-67	1089	30	285.00
	12500	.91	61-71	1134	30	285.00
	13000	1.00	64-74	1179	35	285.00

1. All data is based on the Air Diffusion Council guidelines.
2. Throw data is based on Terminal Velocities of 75 FPM using isothermal air.
3. "Neck Velocity" is the speed in feet per minute of the air coming into the diffusers – similar to duct velocity.*
4. "Jet Velocity" is the speed in feet per minute of the air exiting the diffusers.*
5. Actual noise levels are less than those shown.
6. Throw is based on diffuser blades being directed in a straight pattern.

* Jet velocity is higher than neck velocity on the (510) flush mount diffusers because the air gets "pinched down" as it exits – similar to high pressure water coming out of a garden hose with a sprayer.

The drop down (530) diffusers have enough face area in the supply grills so that the air velocity does not increase significantly as it exits the concentric. That is why "Neck Velocity" and "Jet Velocity" are the same for the drop downs.

530 & 535 Series

SIDE DISCHARGE CONCENTRIC DIFFUSER SYSTEM WITH FILTER GRILL

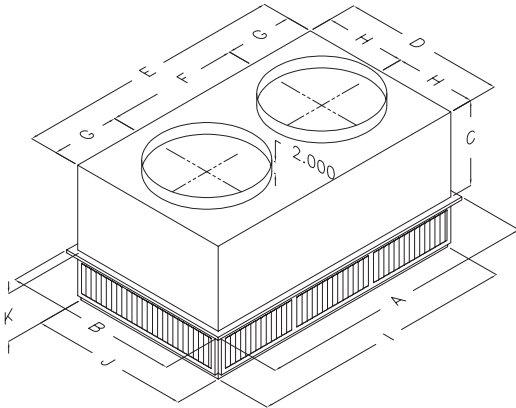

Dimensional Data

MODEL #	A	B	C	D	E	F	G	H	I	J	K	DUCT SIZE
01-530-16 01-535-16	47 5/8	23 5/8	11 3/8	21 1/2	45 1/2	22 1/2	11 1/2	10 3/4	45 1/2	21 1/2	7 1/8	16 RD
01-530-18 01-535-18	47 5/8	23 5/8	11 3/8	21 1/2	45 1/2	22 1/2	11 1/2	10 3/4	45 1/2	21 1/2	7 1/8	18 RD
01-530-20 01-535-20	47 5/8	29 5/8	14 3/8	27 1/2	45 1/2	22 1/2	11 1/2	13 3/4	45 1/2	27 1/2	8 1/8	20 RD

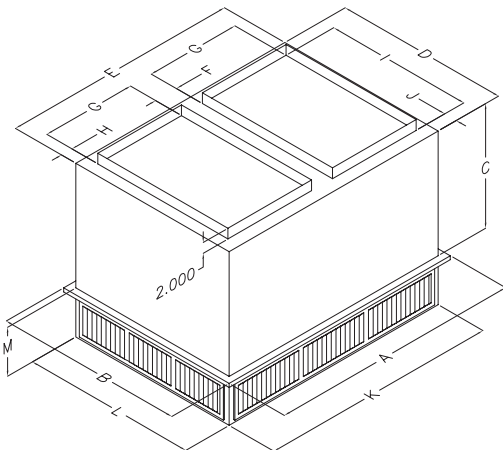

Dimensional Data

MODEL #	A	B	C	D	E	F	G	H	I	J	K	L	M	DUCT SIZE
01-530-22 01-535-22	47 5/8	35 5/8	20 5/8	33 1/2	45 1/2	4 1/2	18	2 1/2	28	2 3/4	45 1/2	33 1/2	9 1/8	18x28
01-530-50 01-535-50	47 5/8	41 5/8	24 5/8	39 1/2	45 1/2	4 1/2	18	2 1/2	32	3 3/4	45 1/2	39 1/2	9 1/8	18x32
01-530-60 01-535-60	47 5/8	47 5/8	24 5/8	45 1/2	45 1/2	4 1/2	18	2 1/2	36	4 3/4	45 1/2	45 1/2	10 1/8	18x36
01-530-80 01-535-80	59 5/8	59 5/8	30 5/8	57 1/2	57 1/2	4 1/2	24	2 1/2	48	4 3/4	57 1/2	57 1/2	11 1/8	24x48
01-530-100 01-535-100	59 5/8	59 5/8	30 5/8	57 1/2	57 1/2	4 1/2	24	2 1/2	54	1 3/4	57 1/2	57 1/2	11 1/8	24x54
01-530-300 01-535-300	65 5/8	65 5/8	40 1/2	63 1/2	63 1/2	4 1/2	28	1 1/2	60	1 3/4	63 1/2	63 1/2	12 1/8	28x60