

**RSI** ROOFTOP  
SYSTEMS, INC.  
*A Ruskin Company*



300-6,200 cfm

*The Rooftop Systems*  
**UnitizedERV**   
*Energy Recovery Ventilator Advantage*



# UnitizedERV

Regardless of building type or rating system, today's building must be as energy efficient as possible. The design of the HVAC system is critical to the success of the building's energy performance. Proper ventilation for occupant health and productivity must also be addressed. The quality of the indoor environment cannot be sacrificed for the sake of energy efficiency.

UnitizedERV by RSI Rooftop Systems is your solution. Increased ventilation rates in combination with energy recovery products not only improve the indoor air quality but also reduce the cost associated with conditioning these larger amounts of outdoor air.

## Benefits of Energy Recovery

### Energy savings provide exceptional payback

Investing in energy recovery wheels in HVAC systems can provide quick payback in two areas.

- Reduces cooling load at design temps up to 4 tons per 1,000 cfm of outside air.
- Reduces heating load up to 12,000 Btuh per 400 cfm of outside air.
- Initial cost savings can be achieved on main air handling units by reducing cooling load. Application software is available to calculate the load reductions and provide the energy and dollar savings in most areas of the United States and Canada. Download free application software at [www.rooftopsystems.com](http://www.rooftopsystems.com).
- Annual savings are achieved by preconditioning the outdoor air.

### LEED-EB and LEED-NC Credits

For Green Building designs, the UnitizedERV can assist the designer in acquiring credits for Energy and Atmosphere (EA) by optimizing energy performance and for Indoor Environmental Quality (IEQ) by providing the ability to increase ventilation leading to thermal comfort.

### ASHRAE Compliance and IAQ

ERV's are an excellent choice to comply with outdoor ventilation requirements of ASHRAE 62. Introducing fresh, outdoor air to a building is a key component in sustaining excellent IAQ and occupant productivity. ERV's meet the minimum requirements for energy savings per ASHRAE 90.1 and will be a preferred method for saving energy in ASHRAE/USGBC/IESNA's new Standard 189.1 – *Standard for the Design of High Performance, Green Buildings Except Low-Rise Residential Buildings*.

TYPICAL HVAC SYSTEM USING ENERGY RECOVERY - SUMMER OPERATION

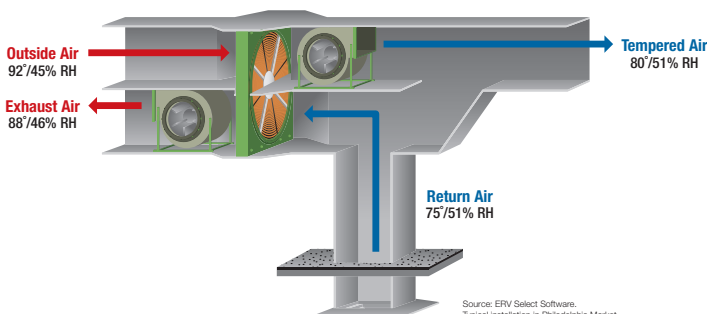

TYPICAL HVAC SYSTEM USING ENERGY RECOVERY - WINTER OPERATION

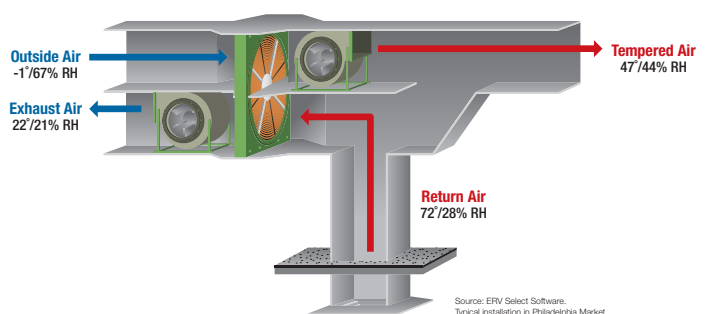

# PRODUCT FEATURES

## STANDARD DESIGN FEATURES

- Built with heavy gauge galvanized steel cabinet with powder paint color-matched to any manufacturer's rooftop unit.
- Powered by Lau Forward Curved Blowers to reduce noise and vibration.
- All controls required to operate the unit and interface with the rooftop unit are factory installed.
- Comes with an interface wiring harness that connects the economizer directly to the ERV with a single plug (P models).
- Adjustable motor sheaves so technicians can easily adjust blower speed.
- Adjustable motor base allows technician to easily adjust belt tension.
- Balancing damper provided for proper air distribution while ERV is in operation (R models only).

## ADDITIONAL DESIGN FEATURES

- **Patented Pivoting Wheel** — Allows the enthalpy wheel to pivot out of the airstream during economizer mode for true economizer operation.
- **Stop-Start-Jog** — Rotates the enthalpy wheel on a preset timer to prevent contamination of the wheel during economizer operation.
- **Electronic Fan Inlet Air & Temperature Measuring Station (EFAMS)** — Ruskin's EFAMS device averages multiple velocity and temperature points at the fan inlet bell to provide highly accurate air measurement, and the output is digitally displayed on the LCD display on the EFAMS control transmitter.
- **Hinged Access Panels** — Give tool-free access for easy maintenance (available on P/R28 and P/R36 models).
- **Low Ambient Control Kit** — prevents frost formation on energy wheel if discharge air temperature falls below a field-selectable temperature setting.
- **Motorized Intake and Exhaust Dampers** — Automatically open when UERV is operating and close when UERV is not operating.
- **Factory Installed Filters** — 2" MERV 8 filters for exhaust sections (select models).
- **Variable Frequency Drive (VFD)** — VFDs control the speed of the blower, and can be integrated with the building's automation system to maximize efficiency and deliver precisely the amount of air needed.
- **CO<sub>2</sub> Sensor** — A CO<sub>2</sub> sensor can help control indoor air quality by bringing on the ERV when CO<sub>2</sub> levels are too high in the occupied space.
- **Wheel Rotation Sensor** — This electronic sensor will send an error signal when the wheel stops turning during ERV operation.
- **Sensible Only Energy Wheel** — The standard Energy Recovery Cassette without the desiccant coating, for use in areas with high internal humidity such as pools, locker rooms and saunas.
- **Smoke Detector** — Duct mounted smoke detectors can be installed in both the supply and return air stream, and they will signal the ERV to start up or shut down when smoke is detected.
- **Pressure Gauge** — A factory installed pressure gauge will show the technician the pressure drop across the wheel, which can help in determining when maintenance is required.

Additional Design Features	Model	Model		Model		Model		Model		Model			
	R06	R11	P11	R20	P20	R28	P28	R36	P36	R46	P46	R62	P62
CFM Range	300-500	700-1000		1000-1700		1500-2800		2800-3600		3400-4600		4800-6200	
Patented Pivoting Wheel			●		●		●		●		●		●
Stop-Start-Jog	●	●		●		●		●		●		●	
Electronic Fan Inlet Air & Temperature Measuring Station (EFAMS)				●	●	●	●	●	●	●	●	●	●
Hinged Access Panels		Call	Call	Call	Call	●	Call	●	●	Call	Call	Call	Call
Low Ambient Control Kit	●	●	●	●	●	●	●	●	●	●	●	●	●
Motorized Intake and Exhaust Dampers Exhaust Motor	●	●	●	●	●	●	●	●	●	●	●	●	●
Factory Installed Filters		●		●		●		●		●		●	
Variable Frequency Drive (VFD)				●	●	●	●	●	●	●	●	●	●
CO <sub>2</sub> Sensor	●	●	●	●	●	●	●	●	●	●	●	●	●
Wheel Rotation Sensor	●	●	●	●	●	●	●	●	●	●	●	●	●
Sensible Only Energy Wheel	●	●	●	●	●	●	●	●	●	●	●	●	●
Smoke Detector	●	●	●	●	●	●	●	●	●	●	●	●	●
Pressure Gauge	●	●	●	●	●	●	●	●	●	●	●	●	●

Note: P models include the Pivoting Wheel option. R models are non-Pivoting Wheel.

■ Standard Design Features

● Additional Options

■ Lifting lugs factory-installed for easy lifting of UERV onto roof.

■ Cabinet is built with heavy gauge, galvanized steel and finished with powder paint.

■ The RSI Unitized ERV fits perfectly with any brand of rooftop unit.

● Hinged access panels offer tool-free access for easy maintenance. Available on P/R28 and P/R36 models.

● Equipment support base provides additional weight support for UERV.

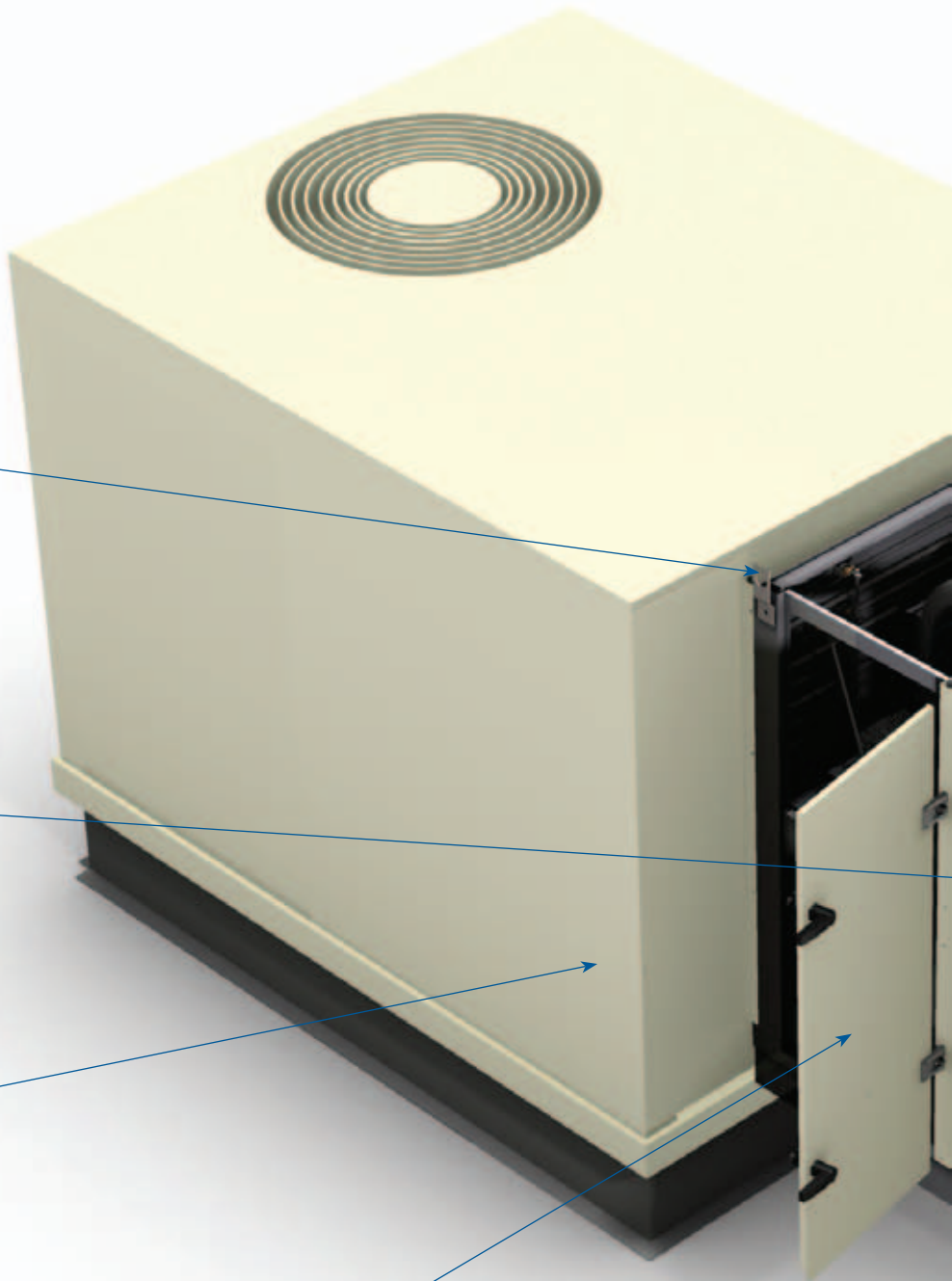

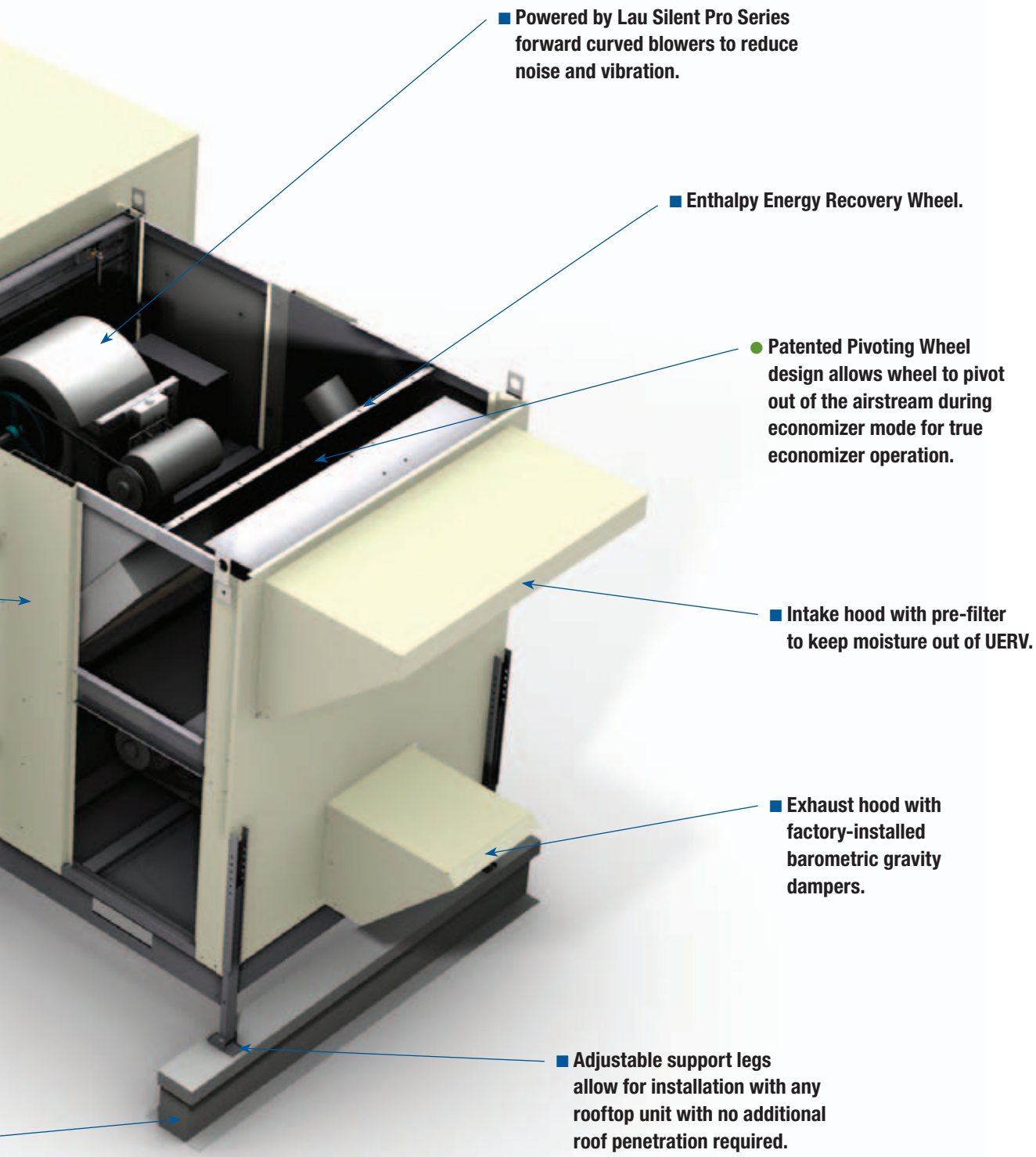

■ Powered by Lau Silent Pro Series forward curved blowers to reduce noise and vibration.

■ Enthalpy Energy Recovery Wheel.

● Patented Pivoting Wheel design allows wheel to pivot out of the airstream during economizer mode for true economizer operation.

■ Intake hood with pre-filter to keep moisture out of UERV.

■ Exhaust hood with factory-installed barometric gravity dampers.

■ Adjustable support legs allow for installation with any rooftop unit with no additional roof penetration required.

# SPECIFICATIONS

## Unitized ERV

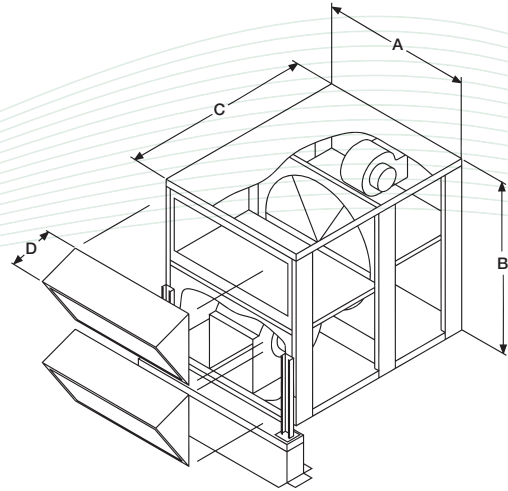

### DIMENSIONS *Inches (Millimeters)*

UERV Series	CFM	A	B	C	D
R06	300-550	24.75 (629)	24.63 (626)	34.56 (878)	8.00 (203)
R11	700-1000	32.13 (816)	33.50 (851)	44.75 (1137)	11.00 (279)
P11					
R20	1000-1700	37.25 (946)	37.50 (953)	54.38 (1381)	20.32 (516)
P20					
R28	1500-2800	42.63 (1083)	43.56 (1106)	52.25 (1327)	18.32 (465)
P28					
R36	2800-3600	46.68 (1186)	57.38 (1457)	60.00 (1524)	18.32 (465)
P36					
R46	3400-4600	52.68 (1338)	57.38 (1457)	60.00 (1524)	18.32 (465)
P46					
R62	4800-6200	58.88 (1496)	57.38 (1457)	60.00 (1524)	18.32 (465)
P62					

### PERFORMANCE DATA

Model		R06	R11/P11	R20/P20	R28/P28	R36/P36	R46/P46	R62/P62
CFM Range	MIN	300	600	1,100	1,500	2,800	3,400	4,800
	MAX	550	1,000	1,700	2,800	3,600	4,600	6,200
Supply Motor HP		0.25	0.5	1	1.5	2	3	5
Exhaust Motor HP	Stationary	0.25	0.5	1	1.5	2	3	5
	Pivoting	N/A	0.5	1.5	3	3	5	(2) 5
Approx. Weight (lbs)		198	245	345	395	475	805	1075

