

# INSTALLATION INSTRUCTIONS

0-35% MOTORIZED FRESH AIR DAMPER  
# 547840  
FOR USE ON PACKAGE EQUIPMENT MODELS  
R6G(D,F,I) / R8GD / R8HE / P6SD / Q6SD 024-060

FORM# 598A-0713 (REPLACES 598A-0512)

The 0-35% outside air damper system is designed to fit over the opening in the horizontal return air panel by replacing the unit horizontal return air duct cover. Slight field modification to the unit is required. The amount of outside air allowed into the occupied space is easily controlled by adjusting the two slide dampers included with the kit. The 2 position motor closes upon loss of 24VAC power when unit is not in heating or cooling mode thus eliminating unwanted drafts into the airstream. The panel is fully insulated.

## Step 1:

Check for correct number of parts. See list below:

- 1 ea. - Outside Air Intake panel assembly with hood, damper motor, and slide dampers.

## Step 2:

Remove the return air duct cover from unit and retain the screws for later use.

## Step 3:

Remove the return air panel from the unit. Locate unit accessory plug at top of return air compartment and connect to fresh air accessory low voltage plug per diagram on back of this instruction sheet.

**Note:** *On shorter models it may be possible to snap lock the two connecting plugs without removal of the return air panel by reaching up through the horizontal return air opening.*

## Step 4:

Using a pair of 3"-4" flat sheet metal crimping pliers carefully form the 90 Deg. mounting flanges outward along the perforated lines around the full perimeter of the horizontal return air opening.

## Step 5:

Install outside air intake hood assembly as shown in **Figure 1** over duct opening and attach with screws removed in Step 2. Screws should attach to formed flanges to avoid possible damage to internal components of the unit.

## Step 6:

Adjust slide dampers to the desired position allowing the correct amount of fresh air into the return airstream to meet requirements of the building. CFM and percentage of fresh air can be determined through the following guidelines with the use of basic equipment. Temperature measurements for the outdoor fresh air and indoor return air are required to calculate the resultant supply air temperature while only the indoor blower is operating. No mechanical cooling should be operating while adjusting the damper blades position.

## Warning:

**Recognize this symbol as an indication of Important Safety Information!**

- Read all instructions prior to installation.
- Disconnect electrical power to the unit before servicing.
- Failure to do so can cause electrical shock resulting in personal injury or death.
- Improper installation, adjustment, alteration, service or maintenance can cause injury or property damage. Refer to this manual. For assistance or additional information consult a qualified installer or service agency.

**DO NOT DESTROY. PLEASE READ CAREFULLY AND**

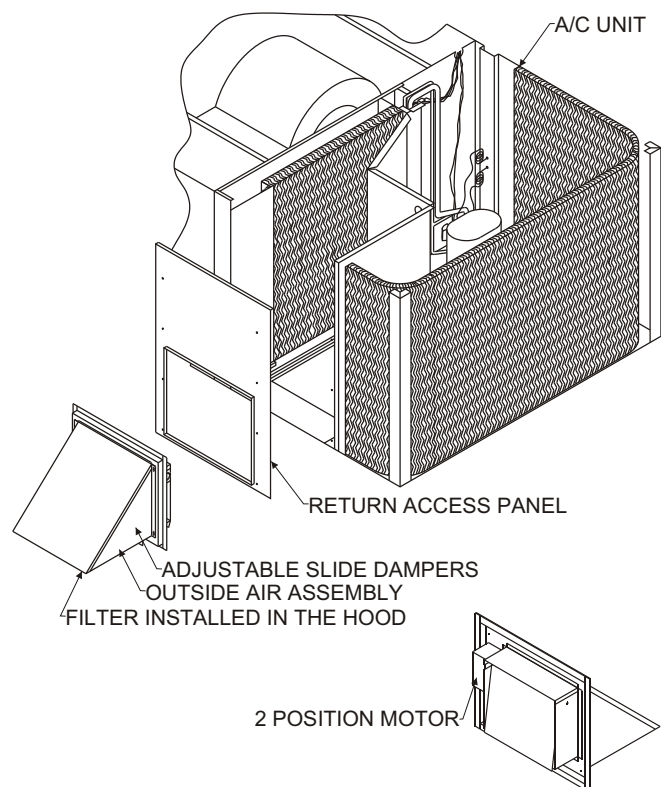

FIGURE 1

# INSTALLATION INSTRUCTIONS

0-35% MOTORIZED FRESH AIR DAMPER  
# 547840  
FOR USE ON PACKAGE EQUIPMENT MODELS  
R6G(D,F,I) / R8GD / R8HE / P6SD / Q6SD 024-060

## Fresh Air Damper Position Adjustment

Slide damper position for ventilation of building contaminants and people occupancy can be adjusted to the proper CFM requirements using the following guidelines. Consult your State or local codes as required.

1. Disconnect main power to the unit.
2. Set the thermostat Fan switch to "ON" or place a jumper across "R" and "G" at the unit low voltage terminal strip.
3. Restore power to the unit. Blower should energize and run continuously while the motorized damper moves to the open position.

Calculate the appropriate mixed air temperature per the following equation:

$$* (\text{Return Air Temp.} \times \% \text{ of Return Air}) + (\text{Outside Air Temp.} \times \% \text{ of Outside Air}) = \text{Mixed Air Temperature}$$

### Example:

Assume local code requires 10% outdoor air during occupied conditions, (200 CFM of total unit CFM = 2,000) outdoor air is 50 Deg. F, and return air is 75 Deg. F.

Under these conditions, what is the mixed air temperature in the supply duct?

$$* (50 \text{ Deg. F} \times 0.1) + (75 \text{ Deg. F} \times 0.9) = 5.0 \text{ Deg. F} + 67.5 \text{ Deg. F} = 72.5 \text{ Deg. F}$$

Adjust the slide damper position until the mixed supply air temperature reaches the calculated value.

**Note: It will be necessary to remove the intake hood so the second slide damper can be removed, if the full amount of outside air is required.**

4. Once damper adjustments are completed, turn off power to the outdoor unit. Motorized damper will move to closed position.
5. Remove jumper across "R" & "G" or return thermostat fan switch back to "AUTO" if desired.
6. Restore power back to unit.

HARNESS DETAIL		COMPONENT CODE		WIRE COLOR CODE		Revision	Change	Date
E# = WIRE END DESIGNATION		CC	Compressor Contactor	BLK	Black	A	Added jumper, MAS, and CC	06-26-09
E2 STUD #6 18 Ga. Wire		MAS	Mixed Air Sensor	BLU	Blue	B	Changed Note 2.	07-29-09
E3 Female ¼ Quick Disc.		M847A	Damper Actuator 24V	GRN	Green	C	Changed Note 2.	05-25-12
E4 Male ¼ Quick Disc. Insul		P1	Fresh Air Plug	GRY	Gray	D	Changed Title Block	07-24-13
E6 Wire Nut Size 73B		S1	Unit Fresh Air Plug	ORN	Orange			
				RED	Red			
				VIO	Violet			
				WHT	White			
				YEL	Yellow			

**HARNESS ENDS AT P1**

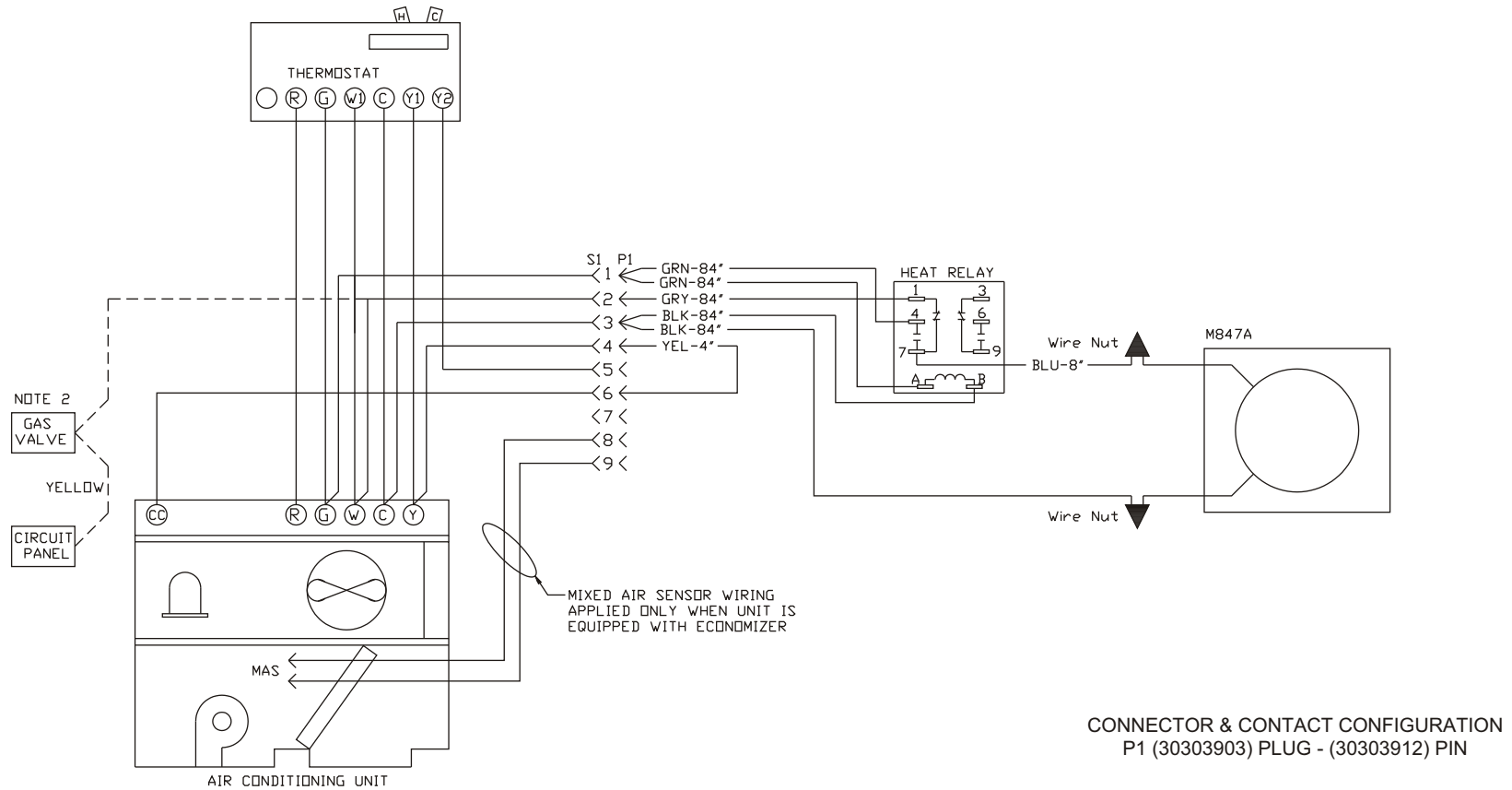

**Notes:**

- Unit wiring shown as reference only. Check unit wiring diagram for actual unit wiring.
- S1 - Pin 2 Connection is :
  - Connection to "yellow" side of gas valve on "R" Series Package Gas/Electric.
  - Connection is at "W" on "Q" and "P" Series units.

**0-35% MOTORIZED FRESH AIR DAMPER  
# 547840  
R6G(D,F,I) / R8GD / R8HE / P6SD / Q6SD 024-060**

Date: July 24, 2013
Supercedes: 05-25-12
Drawn by: MGL
Unit #: 47-287-06
Diagram#: 4728706W
Approved by: